

THIS IS A C.A.D. GENERATED DRAWING  
DO NOT MAKE MANUAL REVISIONS TO MASTER.

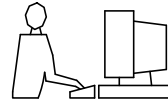

\* UNLESS OTHERWISE SPECIFIED TOLERANCES  
ON DECIMAL IS: X. ±0.20 X. ±2\*  
UNIT: MM X.X ±0.15 X.X\* ±1\*  
X.XX ±0.13 X.XX\* ±0.5\*

ISSUE NUMBER

ORIGINAL

①

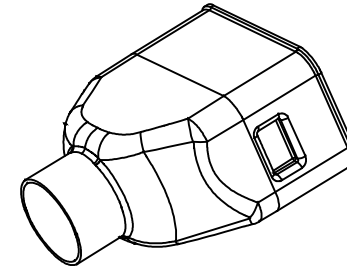
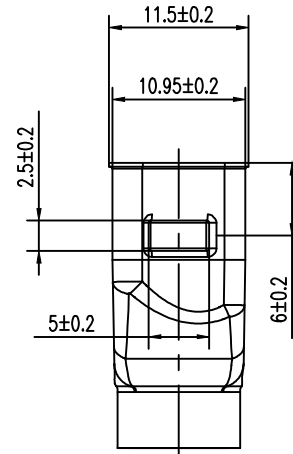
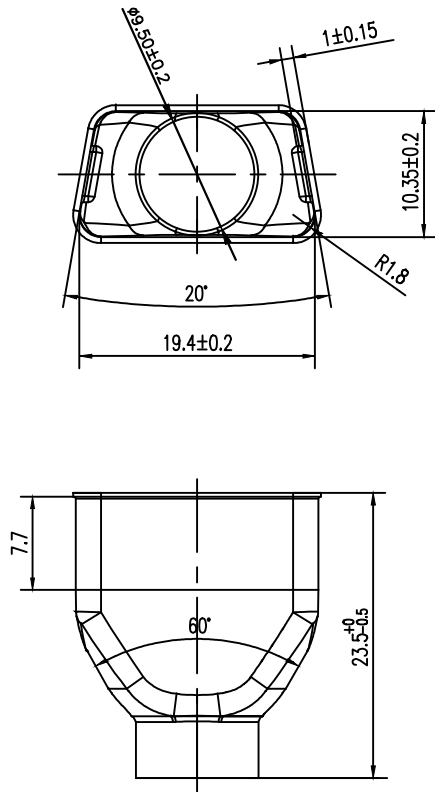

NOTES:

1. MATERIAL : SPCC, T=0.3
2. PLATING : TIN PLATED.
3. THE DIM Ø9.50 POSITION ALLOW CRACKS, BUT CAN'T EFFECT NORMAL USE.

THESE DRAWINGS AND SPECIFICATIONS ARE THE PROPERTY OF MH CONNECTORS AND SHALL NOT BE REPRODUCED, COPIED OR USED AS THE BASIS FOR THE MANUFACTURE OR SALE OF APPARATUS WITHOUT WRITTEN PERMISSION.

DRAWN Iven Ou	DATE 2023/03/14
------------------	--------------------

APPROVED	DATE
----------	------

SCALE	SHEET OF 1 OF 1	REV: 1.0
-------	--------------------	-------------

DRAWING No DMCK09-9.50
---------------------------



THIS SERIES FULLY CONFORMS TO THE EUROPEAN UNION DIRECTIVES 2015/863/EU AND 2011/65/EU FOR RoHS COMPLIANCY.



**MH CONNECTORS ,  
DIVISION OF EDAC**